

38 Frame Block-Style Stainless Steel Plunger Pump

**Standard
Model**

3841

**Flushed
Model**

3841K

FEATURES

Superior Design

- Triplex plunger design provides smoother liquid flow.
- Inlet and discharge valve assemblies interchange for easier maintenance.
- Oil bath crankcase assures optimum lubrication.
- Close tolerance concentricity of the ceramic plunger maximizes seal life.
- **Standard Models:** Lo-Pressure Seals and V-Packings are completely lubricated and cooled by the liquid being pumped.

Flushed Models: Special ported inlet manifold permits liquid to cool or flush between V-Packings and Lo-Pressure Seals providing protection against high temperatures or contaminating pumped liquids.

Quality Materials

- Precision design 316 stainless steel valves and seats are hardened and polished for ultimate seating and extended valve life.
- 316 SSL block-style manifolds for strength and corrosion resistance.
- Special concentric, high density, polished, graphite impregnated, solid ceramic plungers are abrasion resistant and result in extended seal life.
- Specially formulated, CAT PUMP exclusive, V-Packings offer unmatched performance and seal life.
- Die cast aluminum crankcase provides high strength, minimum weight and precision tolerance control.
- Chrome-moly crankshaft gives unmatched strength and surface hardness.
- Oversized crankshaft bearings with greater loading capacity means longer bearing life.

Easy Maintenance

- Wet-end is easily serviced without entering crankcase, requiring less time and effort.
- Preset packings mean no packing gland adjustment is necessary, reducing maintenance costs.

⚠ WARNING

All systems require both a primary pressure regulating device (i.e., regulator, unloader) and a secondary pressure safety relief device (i.e., pop-off valve, safety valve). Failure to install such relief devices could result in personal injury or damage to the pump or to system components. CAT PUMPS does not assume any liability or responsibility for the operation of a customer's high pressure system.

SPECIFICATIONS

	U.S. Measure	Metric Measure
Flow	45 GPM	(170 L/M)
Pressure Range	100 to 1000 PSI	(7 to 70 BAR)
Inlet Pressure*	Flooded to 70 PSI	(Flooded to 4.9 BAR)
RPM	765 RPM	(765 RPM)
Bore	1.772"	(45 mm)
Stroke	1.890"	(48 mm)
Crankcase Capacity	4.2 Qts.	(4 L)
Maximum Liquid Temperature	140°F	(60°C)
Above 130°F call CAT PUMPS for inlet conditions and elastomer recommendations.		
Inlet Ports (2)	1-1/2" NPTF	(1-1/2" NPTF)
Flushing Ports (2)	1/2" NPTF	(1/2" NPTF)
Discharge Ports (2)	1" NPTF	(1" NPTF)
Pulley Mounting	Either Side	(Either Side)
Shaft Diameter	1.378"	(35 mm)
Weight	139 lbs.	(63 kg)
Dimensions	24.4 x 18.11 x 9.37"	(620 x 460 x 238 mm)

*"K" Models have special inlet ports for cooling/flushing, containment of hazardous liquids and high inlet pressure. Contact CAT PUMPS for additional information.

HORSEPOWER REQUIREMENTS

FLOW		PRESSURE			RPM
		PSI 800	PSI 900	PSI 1000	
U.S. GPM	L/M	BAR 55	BAR 63	BAR 70	
45	170	24.7	27.8	30.9	765
40	151	22.0	24.7	27.4	680
35	133	19.2	21.6	24.0	595

DETERMINING THE PUMP R.P.M.	$\frac{\text{Rated G.P.M.}}{\text{Rated R.P.M.}}$	=	$\frac{\text{"Desired" G.P.M.}}{\text{"Desired" R.P.M.}}$
DETERMINING THE REQUIRED H.P.	$\frac{\text{GPM x PSI}}{1460}$	=	Electric Brake H. P. Required
DETERMINING MOTOR PULLEY SIZE	$\frac{\text{Motor Pulley O.D.}}{\text{Pump R.P.M.}}$	=	$\frac{\text{Pump Pulley O.D.}}{\text{Motor R.P.M.}}$

See complete Drive Packages [Incls: Pulleys, Belts, Hubs, Key] Tech Bulletin 003.
Refer to pump Service Manual for repair procedure and additional technical information.

"Customer confidence is our greatest asset"

PARTS LIST

ITEM	PART NUMBER		DESCRIPTION		QTY	
	3841	MATL	3841K	MATL		
2	30055	STL	30055	STL	Key (M10x6x32)	1
	34021	STL	34021	STL	Key (M10x8x70)	1
5	118824	S	118824	S	Screw, Sems HH (M8x25)	8
8	44542	AL	44542	AL	Cover, Bearing	2
9	44543	FBR	44543	FBR	Shim, Split 2-Pc	4
10	12398	NBR	12398	NBR	O-Ring, Bearing Cover - 70D	2
11	13296	NBR	13296	NBR	Seal, Oil, Crankshaft	2
15	29326	STL	29326	STL	Bearing, Roller	2
20	121467	TNM	121467	TNM	Assembly, Connecting Rod (Incls: 21,22,23) [10/00]	3
21	44940	STZP	44940	STZP	Washer, Locking (M10)	3
22	12490	STZP	12490	STZP	Washer, Flat (M10)	6
23	122045	STZP	122045	STZP	Screw, Con Rod, HH (M10x55)	6
25	29325	FCM	29325	FCM	Crankshaft, Dual End	1
31	828710	—	828710	—	Protector, Cap	1
32	43211	ABS	43211	ABS	Cap, Oil Filler	1
33	14177	NBR	14177	NBR	O-Ring, Oil Filler Cap - 70D	1
34	44319	STZP	44319	STZP	Bolt, Eye (M12)	1
37	92241	—	92241	—	Gauge, Oil, Bubble w/Gasket - 80D	1
38	44428	NBR	44428	NBR	Gasket, Flat - 80D	1
40	118824	S	118824	S	Screw, Sems HH (M8x25)	8
48	25625	STCP	25625	STCP	Plug, Drain (1/4"x19BSP)	1
49	23170	NBR	23170	NBR	O-Ring, Drain Plug - 70D	1
50	45936	AL	45936	AL	Cover, Rear	1
51	16612	NBR	16612	NBR	O-Ring, Rear Cover - 70D	1
53	44559	AL	44559	AL	Crankcase	1
55	27488	S	27488	S	Pins, Guide	2
64	43864	CM	43864	CM	Pin, Crosshead	3
65	45116	SSZZ	45116	SSZZ	Rod, Plunger	3
69	29338	STZP	29338	STZP	Seal, Washer, Oil	3
70	100488	NBRS	100488	NBRS	Seal, Oil, Crankcase	3
	44739	FPM	44739	FPM	Seal, Oil, Crankcase	3
75	43865	S	43865	S	Slinger, Barrier	3
88	45676	SS	45676	SS	Washer, Keyhole (M16)	3
90	46806	CC	46806	CC	Plunger (M45x145)	3
95	89778	SS	89778	SS	Stud, Plunger Retainer (M10x135)	3
96	20189	PTFE	20189	PTFE	Back-up-Ring, Plunger Retainer	3
97	11345	NBR	11345	NBR	O-Ring, Plunger Retainer - 70D	3
	11375	FPM	11375	FPM	O-Ring, Plunger Retainer	3
	◆ 701490	EPDM	◆ 701490	EPDM	O-Ring, Plunger Retainer	3
98	44085	SS	44085	SS	Gasket, Plunger Retainer	3
99	44084	SS	44084	SS	Retainer, Plunger (M10)	3
100	44119	PVDF	44119	PVDF	Retainer, Seal	3
106	48384	NBR	48384	NBR	Seal, LPS w/SS-Spg	3
	702013	SFTB*	702013	SFTB*	Seal, LPS w/SS-Spg	3
	◆ 46945	EPDM	◆ 46945	EPDM	Seal, LPS w/SS-Spg	3
107	48380	D	48380	D	Spacer, LPS	3
110	701865	SSL	—	—	Manifold, Inlet, Block-Style	1
	—	—	701982	SSL	Manifold, Inlet, Block-Style, Flushed	1
111	701116	SS	701116	SS	Plug, Inlet (1-1/2" NPT)	1
112	701632	NBR	701632	NBR	O-Ring, Inlet Spacer	6
	701328	FPM	701328	FPM	O-Ring, Inlet Spacer	6
	◆ 701659	EPDM	◆ 701659	EPDM	O-Ring, Inlet Spacer - 70D	6
113	701329	PTFE	701329	PTFE	Back-up-Ring, Inlet Spacer	6
114	701327	SS	701327	SS	Spacer, Inlet	3
117	44585	S	44585	S	Screw, HSH (M14x40)	4
126	48383	D	48383	D	Adapter, Female	3
127	46813	STG*	46813	STG*	V-Packing	6
128	48386	SS	48386	SS	Adapter, Male	3
141	45113	SS	45113	SS	Spring, Coil	6/18
142	48382	SS	48382	SS	Spacer w/Coil Springs	3
155	17784	NBR	17784	NBR	O-Ring, Spacer - 80D	3
	20138	FPM	20138	FPM	O-Ring, Spacer - 80D	3
	◆ 701658	EPDM	◆ 701658	EPDM	O-Ring, Spacer - 80D	3
157	48381	SS	48381	SS	Spacer, V-Packing	3
159	17784	NBR	17784	NBR	O-Ring, Spacer - 80D	3
	20138	FPM	20138	FPM	O-Ring, Spacer - 80D	3
	◆ 701658	EPDM	◆ 701658	EPDM	O-Ring, Spacer - 80D	3
163	26143	NBR	26143	NBR	O-Ring, Seat	6
	14331	FPM	14331	FPM	O-Ring, Seat	6
	◆ 701660	EPDM	◆ 701660	EPDM	O-Ring, Seat	6
164	48393	SS	48393	SS	Seat	6
166	44108	SS	44108	SS	Valve	6
167	44109	SS	44109	SS	Spring	6
168	44728	PVDF	44728	PVDF	Retainer, Spring	6
170	44729	SS	44729	SS	Washer, Spring Retainer	6
171	44644	SS	44644	SS	Spring, Coil (70kg), Valve Plug	6
172	89827	NBR	89827	NBR	O-Ring, Valve Plug - 90D	6
	11747	FPM	11747	FPM	O-Ring, Valve Plug - 90D	6
	◆ 701494	EPDM	◆ 701494	EPDM	O-Ring, Valve Plug - 70D	6
173	48364	D	48364	D	Back-up-Ring, Valve Plug	6
174	701278	SS	701278	SS	Plug, Valve	6
176	701316	SS	701316	SS	Cover, Valve	2
177	87951	S	87951	S	Screw, HSH (M10x30)	32
185	701866	SSL	701866	SSL	Manifold, Discharge, Block-Style	1
188	701279	S	701279	S	Screw, HSH (M12x100)	8
196	701342	SS	701342	SS	Plug, Discharge (1" NPT) Not Shown	1

Replace as a set

EXPLODED VIEW

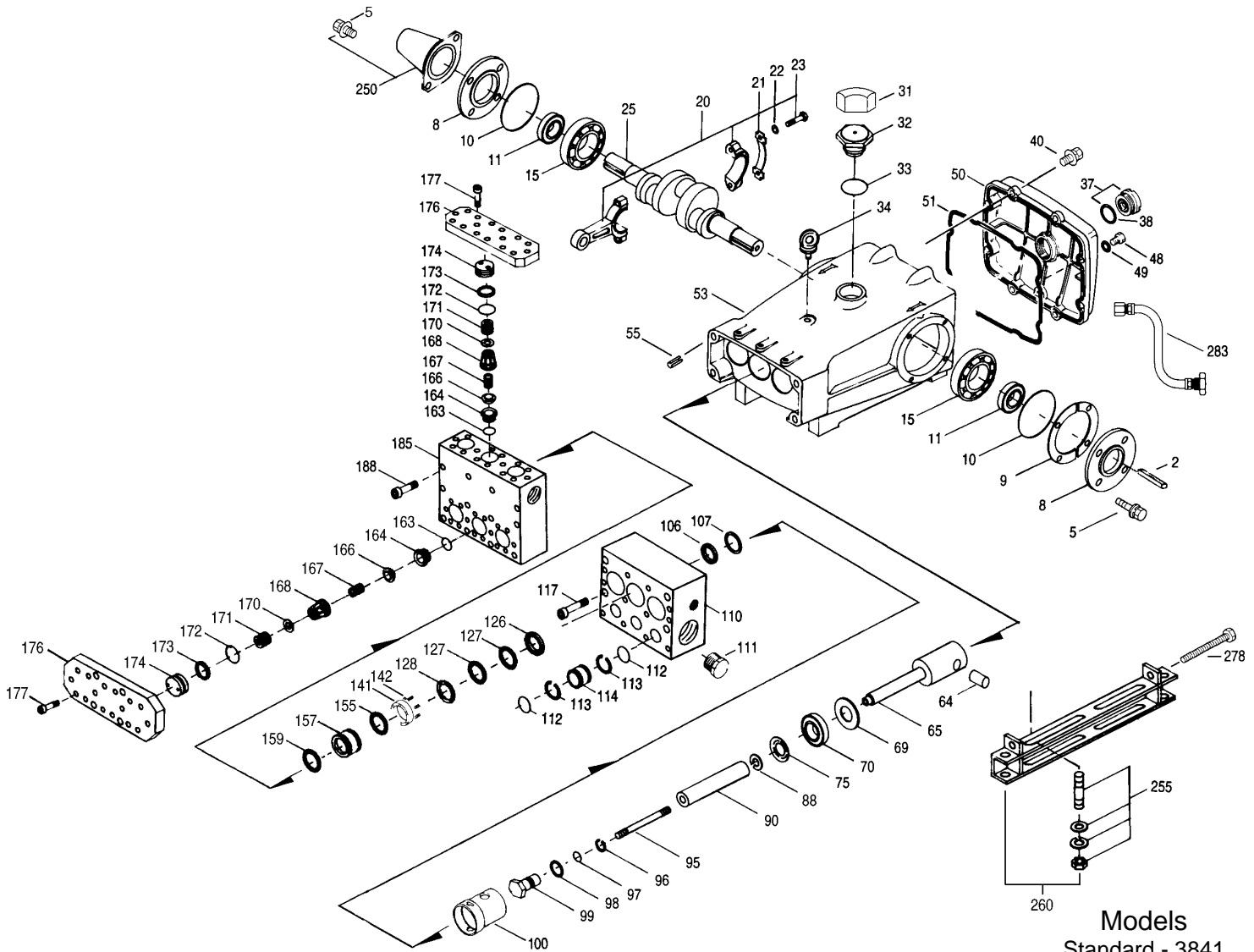

Models
Standard - 3841
Flushed - 3841K
June 2004

	3841	MATL	3841K	MATL		
250	44516	NY	44516	NY	Protector, Shaft w/2 89283 Screws (Included with Pump)	1
255	34039	SS	34039	SS	Kit, Stud Mount	1
260	92674	STZP	92674	STZP	Mount, Rail Assy (Incls: 43888, 34018)	1
275	990013	STL	990013	STL	Hub, "B" (Keyway M10x8x70) [See Drive Packages Tech Bulletin 003]	1
278	80540	ZP	80540	ZP	Screw, HH (M12x100) (Rail Adjusting Screw)	1
283	34334	—	34334	—	Kit, Oil Drain	1
290	6104	—	6104	—	Gasket, Liquid (1 oz.)	1
299	901410	SSL	—	—	Head, Complete, Block-Style	1
	—	—	901411	SSL	Head, Complete, Block-Style, Flushed	1
300	31934	NBR*	31934	NBR*	Kit, Seal (Incls: 97, 106, 112, 113, 127, 155, 159)	1
	31961	FPM*	31961	FPM*	Kit, Seal (Incls: 97, 106, 112, 113, 127, 155, 159)	1
	◆ 31923	EPDM*	◆ 31923	EPDM*	Kit, Seal (Incls: 97, 106, 112, 113, 127, 155, 159)	1
310	33835	NBR	33835	NBR	Kit, Valve (Incls: 163, 164, 166, 167, 168, 170, 172, 173)	2
	31262	FPM	31262	FPM	Kit, Valve (Incls: 163, 164, 166, 167, 168, 170, 172, 173)	2
	◆ 31264	EPDM	◆ 31264	EPDM	Kit, Valve (Incls: 163, 164, 166, 167, 168, 170, 172, 173)	2
—	819000	F	819000	F	Assembly, Crankcase, CAST IRON Conversion	1
370	—	—	990663	—	Assembly, Flushing, 5 gal., 115V, 1.1 Amp, 1/2" NPT	1
—	714500	SS	714500	SS	C.A.T. (For R.O. or Industrial Applications)	1
—	714506	SS	714506	SS	Adapter (2 per C.A.T.) (See Data Sheet for complete selection)	2
—	6100	—	6100	—	Oil, Case (12-21 oz. Bottles) ISO 68 Multi-Viscosity Hydraulic (Fill to specified crankcase capacity prior to start-up)	1

Bold print part numbers are unique to a particular pump model. Italics are optional items. ◆ Silicone oil/grease required.
[] Date of Latest production change. *Review material codes for individual items (STG and SFTB generally may be used as alternates).

C.A.T. highly recommended for pressurized inlet, R.O. and industrial applications.

See Tech Bulletins 002, 003, 024, 036, 043, 053, 074, 077 and 083 for additional information.

MATERIAL CODES (Not Part of Part Number): ABS=ABS Plastic AL=Aluminum CC=Ceramic CM=Chrome-moly D=Acetal EPDM=Ethylene Propylene Diene Monomer
F=Cast Iron FBR=Fiber FCM=Forged Chrome-moly FPM=Fluorocarbon NBR=Medium Nitrile (Buna-N) NY=Nylon NBRSS=Buna, Silicone Free
PTFE=Pure Polytetrafluoroethylene PVDF=Polyvinylidene Fluoride S=304SS SS=316SS SSL=316SS/Low Carbon SFTB=Special Blend PTFE Black SSZZ=316SS/Zamak
STG=Special Blend PTFE White STL=Steel STCP=Steel/Chrome Plated STZP=Steel/Zinc Plated TNM=Special High Strength

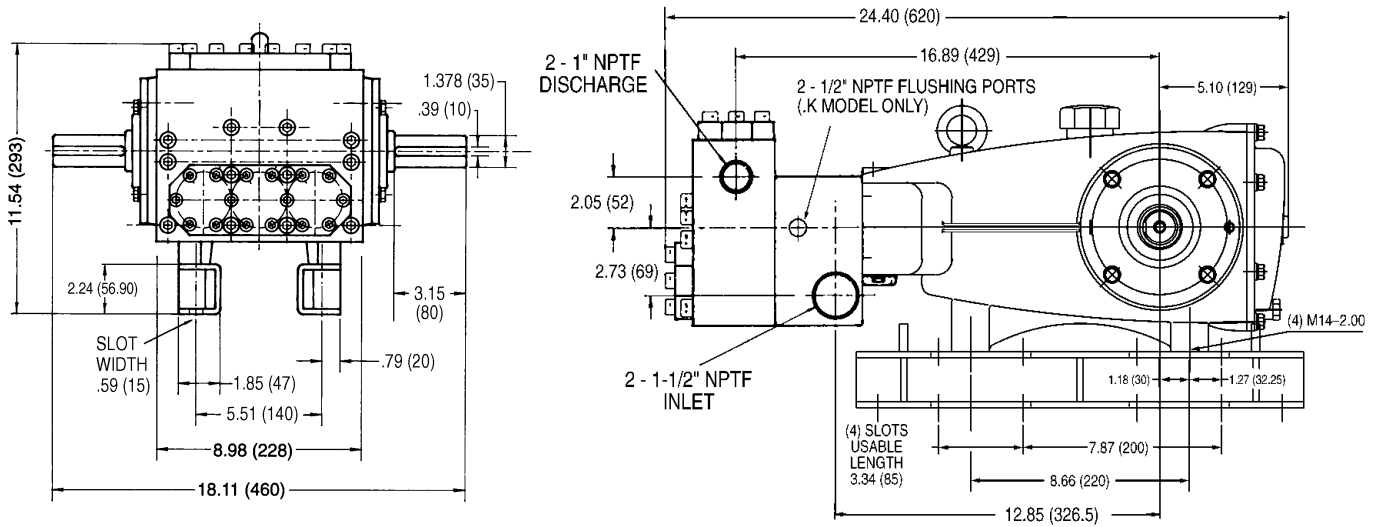

Models 3841, 3841K

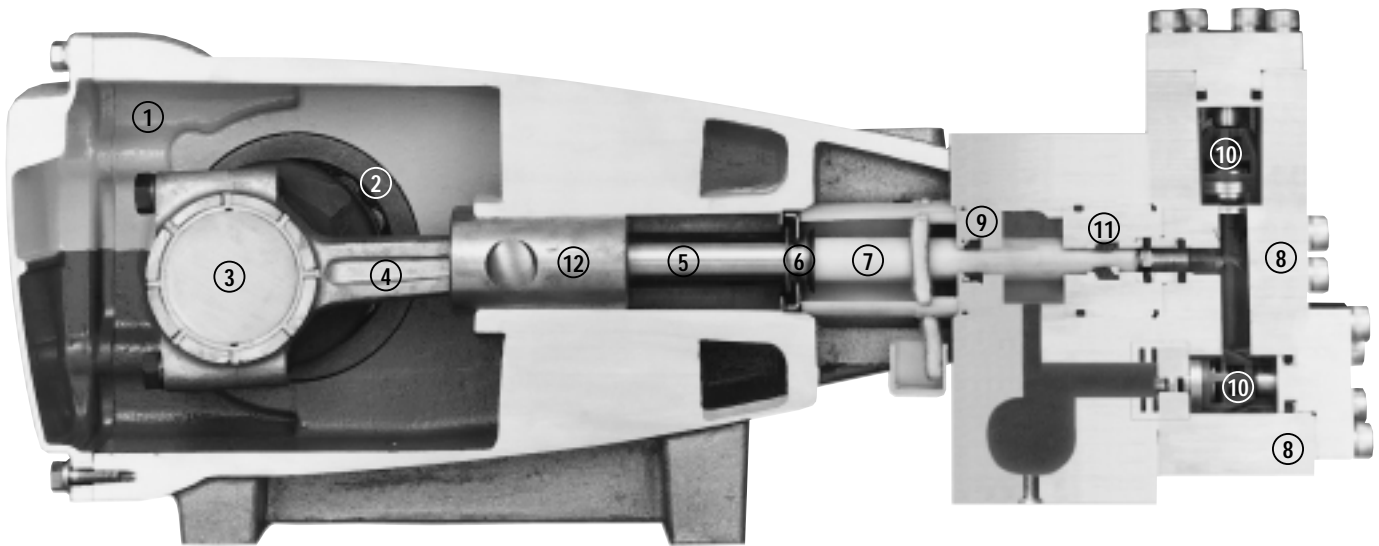

- 1 Die cast aluminum **crankcase** means high strength, lightweight, and excellent tolerance control.
- 2 Oversized crankshaft **bearings** provide extended bearing life and pump performance.
- 3 Chrome-moly **crankshaft** provides unmatched strength and surface hardness for long life.
- 4 Matched oversized high strength TNM **connecting rods** are noted for superior strength and bearing quality.
- 5 Special stainless steel **plunger rods** with high strength crossheads for longevity and corrosion resistance.
- 6 The stainless steel **slinger** provides back-up protection for the crankcase seal, keeping pumped liquids out of the crankcase.
- 7 Special concentric, high density, polished, graphite impregnated, solid ceramic **plungers** are abrasion resistant and result in extended seal life.
- 8 **Manifolds** are 316 SSL block-style for long-term, continuous-duty and corrosion resistance.
- 9 **Standard Models:** Lo-Pressure Seals and V-Packings are completely lubricated and cooled by the liquid being pumped.
- 9 **Flushed Models:** Special ported inlet manifold permits liquid to cool or flush between V-Packings and Lo-Pressure Seals providing protection against high temperatures or contaminating pumped liquids.
- 10 Stainless steel **valves, seats and springs** provide corrosion-resistance, ultimate seating and extended life.
- 11 Specially formulated, CAT PUMP exclusive, **V-Packings** offer unmatched performance and seal life.
- 12 **Crossheads** are 360° supported for uncompromising alignment.

Products described hereon are covered by one or more of the following U.S. patents 3558244, 3652188, 3809508, 3920356, 3930756 and 5035580

World Headquarters
CAT PUMPS
 1681 - 94th Lane N.E. Minneapolis, MN 55449-4324
 Phone (763) 780-5440 — FAX (763) 780-2958
 e-mail: techsupport@catpumps.com
 www.catpumps.com



CAT PUMPS (U.K.) LTD.
 1 Fleet Business Park, Sandy Lane, Church Crookham, Fleet
 Hampshire GU52 8BF, England
 Phone Fleet 44 1252-622031 — Fax 44 1252-626655
 e-mail: sales@catpumps.co.uk

N.V. CAT PUMPS INTERNATIONAL S.A.
 Heiveldekens 6A, 2550 Kontich, Belgium
 Phone 32-3-450.71.50 — Fax 32-3-450.71.51
 e-mail: cpi@catpumps.be www.catpumps.be

CAT PUMPS DEUTSCHLAND GmbH
 Buchwiese 2, D-65510 Idstein, Germany
 Phone 49 6126-9303 0 — Fax 49 6126-9303 33
 e-mail: catpumps@t-online.de www.catpumps.de

International Inquiries
 FAX (763) 785-4329
 e-mail: intlsales@catpumps.com