



Pressure Sensitive Regulating Unloader

Models

7670, 7672
7690, 7691

FEATURES

- Provides system pressure setting and protection for single gun (non-weep) and pump installation.
- Compact size with optional ports for easy installation.
- New ergonomic handle permits easy adjustments of pressure.
- Pressure sensitive feature permits wide range of flows and immediate pressure when gun opens.
- Color coded spring for easy identification and simple change from one model to another.
- Also functions as a secondary Relief Valve without the check valve.
- Model 7691 has a quick start valve to relieve pump discharge line pressure at start up.

SPECIFICATIONS

	U.S. Measure	Metric Measure
MODEL 7670		
Flow Range	2.5-8.0 GPM	(9.5-30 L/M)
Pressure Range	150-1750 PSI	(10-120 BAR)
Weight	1.66 lbs.	(0.75 kg)
Dimensions	7.0 x 3.12 x 2.0"	(178 x 79 x 51 mm)
MODEL 7672		
Flow Range	2.5-8.0 GPM	(9.5-30 L/M)
Pressure Range	850-3200 PSI	(60-220 BAR)
Weight	1.72 lbs.	(0.78 kg)
Dimensions	7.0 x 3.12 x 2.0"	(178 x 79 x 51 mm)
MODEL 7690		
Flow Range	2.5-8.0 GPM	(9.5-30 L/M)
Pressure Range	1000-4050 PSI	(70-280 BAR)
Weight	1.75 lbs.	(0.79 kg)
Dimensions	7.0 x 3.12 x 2.0"	(178 x 79 x 51 mm)
MODEL 7691 WITH QUICK START		
Flow Range	2.5-8.0 GPM	(9.5-30 L/M)
Pressure Range	1000-4050 PSI	(70-280 BAR)
Weight	1.75 lbs.	(0.79 kg)
Dimensions	7.0 x 3.12 x 2.0"	(178 x 79 x 51 mm)
COMMON SPECIFICATIONS		
Maximum Temperature	195°F	(90°C)
Inlet Ports (2)	3/8" NPTF	(3/8" NPTF)
Discharge Port (1)	3/8" NPTF	(3/8" NPTF)
By-Pass Port (1)	3/8" NPTF	(3/8" NPTF)

⚠ WARNING

All systems require both a primary pressure regulating device (i.e., regulator, unloader) and a secondary pressure safety relief device (i.e., pop-off valve, safety valve). Failure to install such relief devices could result in personal injury or damage to the pump or to system components. CAT PUMPS does not assume any liability or responsibility for the operation of a customer's high pressure system.

Unloader is stamped with a European safety pressure. Use only at above specifications to assure proper unloader life and performance.

For Relief Valve version add .100 to unloader model number.
For FPM o-ring version add .0110 to unloader model number.

“Customer confidence is our greatest asset”

SELECTION

This is a pressure sensitive regulating unloader designed for systems with single or multiple pumps, solenoid (gate) valves, nozzles, standard or "weep" guns.

This pressure sensitive regulating unloader should meet both the desired system flow (combined nozzle flow rate requirement) and system pressure.

Note: Operation below the minimum flow of the unloader causes the unloader to cycle. Operation above the maximum flows of the unloader causes premature unloader wear, cycling and prevents attaining desired system pressure.

INSTALLATION

This unloader operates properly when mounted in any direction, however, it is preferred to keep the plumbing to a minimum and the adjusting handle easily accessible. The best mounting location is directly on the pump discharge manifold head.

The inlet connections on this unloader are 3/8" NPTF ports and are located on the left side and bottom. Arrows and the word "IN" are cast into the body indicating the direction of flow. A new unloader will have a plug in the bottom port, but this plug can be switched to the left side port if needed. Liquid from the discharge of the manifold goes through these connections.

The discharge connection on this unloader is a 3/8" NPTF port and is located on the front side (hex end). An arrow and the word "OUT" is cast into the body indicating the direction of flow. Plumbing to the spray guns, solenoid (gate) valves or nozzles are connected here.

The by-pass connections on this unloader are 3/8" NPTF ports and are located on the back side and front face. The word "BY PASS" is cast into the body indicating the direction of flow. By-pass liquid is directed out of this port and can be routed to a reservoir (preferred method), or to a drain or to the pump inlet.

OPERATION

This pressure sensitive regulating unloader holds established system pressure in the discharge line when the trigger gun is closed or solenoid (gate) valve is closed or the nozzle is clogged, thus by-passing all unrequired flow. Squeezing the trigger gun or opening the solenoid (gate) valve will close off the by-pass and return to established system pressure without delay.

PRESSURE ADJUSTMENT

1. Setting and adjusting the unloader pressure must be done with the system "on".
2. Start the system with unloader backed off to the lowest pressure setting (counterclockwise direction).
3. Squeeze the trigger and read the pressure on the gauge at the pump.

Note: Do not read the pressure at the gun or nozzle.

4. If more pressure is desired, release the trigger, turn adjusting handle one quarter turn in clockwise direction.
5. Squeeze the trigger and read the pressure.
6. Repeat this process until desired system pressure is attained.
7. Once the desired system pressure is reached, stop turning the adjusting handle.

Note: Pressure is not set at the factory.

CAUTION: A minimum by-pass flow of 5% of the unloader rated flow capacity is required for proper unloader performance. If the entire output is directed through the unloader (zero by-pass) the "cushioning" feature of the by-pass liquid is eliminated and the unloader can malfunction or wear prematurely.

8. If desired system pressure cannot be reached, review TROUBLESHOOTING chart.
9. When servicing existing systems, follow adjustment procedures as stated above for new unloaders.

Note: Do not adjust unloader pressure setting to compensate for a worn nozzle. Check the nozzle as part of the regular maintenance and replace if worn.

Note: A secondary pressure safety relief device (i.e. pop-off valve, safety valve) should be used along with this pressure sensitive regulating unloader. Final adjustment for the relief valve should relieve at 200 psi above the system operating pressure.

TYPICAL UNLOADER INSTALLATION

- 1 Pressure Gauge
- 2 By-Pass Hose
- 3 Thermal Valve
- 4 Pop-off Valve (secondary safety relief valve)
- 5 Triplex Plunger Pump
- 6 Pressure Sensitive Regulating Unloader

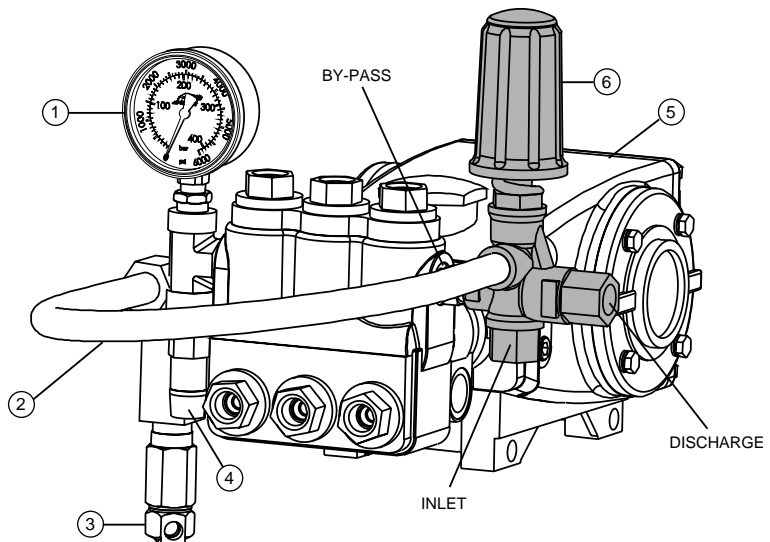

SERVICING

CAUTION: Before commencing with service, shut off drive (electric motor, gas or diesel engine) and turn off water supply to pump. Relieve all discharge line pressure by triggering gun or opening valve in discharge line.

Disassembly:

1. Disconnect by-pass, discharge and inlet plumbing from unloader.
2. Remove unloader from pump.
3. Secure body of unloader in a vise with adjusting handle facing up.
4. Remove discharge fitting and o-ring, spring, check valve and o-ring.
5. Inspect check valve and discharge fitting for wear, spring for wear or fatigue and o-rings for cuts or wear and replace as needed with check valve kit.

Note: While the discharge fitting is removed, inspect sealing area where the check valve makes contact within the internal body of the unloader for grooves, pitting and wear. If damage is found, stop the repair and replace with complete new unloader. If not, proceed with disassembly.

6. Remove black nylon cap on top of adjusting handle.
7. Unscrew and remove hex nylock nut.
8. Unscrew and remove adjusting handle, flat washer and spring.
9. Inspect all parts for scale build up or wear and replace as needed. Examine spring for fatigue or wear and replace as needed.
10. Remove piston lock pin.
11. Unscrew piston retainer from body of unloader.
12. Grasp threaded end of piston stem and pull from body of unloader. Piston retainer and all associated o-rings should come out upon removal.
13. Unscrew and remove two jam nuts from piston stem.
14. Remove piston retainer, o-rings and back-up-ring. Examine piston retainer for wear. Examine o-rings and back-up-ring for cuts or wear and replace as needed.
15. Examine piston stem for wear. Examine o-ring and back-up-rings for cuts or wear and replace as needed.

16. Remove bottom inlet fitting and o-ring, spring, ball and seat w/o-ring from bottom inlet connection. Examine seat for grooves and o-ring for cuts or wear and replace as needed.

Reassembly:

1. At bottom inlet port, lubricate and install o-ring on outside diameter of seat and press seat squarely into position in the body.
2. Install ball and then spring, thread in inlet fitting with o-ring.
3. Lubricate and install back-up-ring and then o-ring into inside diameter of piston retainer. Lubricate and install larger o-ring over threads of piston retainer body. Slide piston retainer with threads facing downwards over piston stem.
4. Apply Loctite®242® to the last few threads of the piston stem. Hand thread two jam nuts to bottom threads of piston stem.
5. Lubricate and install in this order: back-up-ring, o-ring and then back-up-ring onto opposite end of piston stem.
6. Pull piston retainer by hand towards piston stem tip and align slot in piston retainer with hole in piston stem. Install piston lock pin.
7. Grasp threaded end of piston stem and thread in by hand into unloader body, tighten with wrench.
8. Slide spring over piston stem. Install flat washer on top of spring.
9. Thread adjusting handle onto piston stem.
10. Install hex nylock nut onto piston stem.
11. At discharge side of unloader, lubricate and install o-ring onto check valve. Place spring inside check valve. Insert check valve with o-ring and spring into discharge port of unloader body.
12. Lubricate and install o-ring onto threaded end of discharge fitting. Thread in discharge fitting to discharge port of unloader body and tighten with wrench.
13. Remove unloader from vise.
14. Re-install unloader onto pump.
15. Reconnect by-pass, discharge and inlet plumbing to unloader.
16. Proceed to PRESSURE ADJUSTMENT.

Loctite® and 242® are registered trademarks of the Henkel Corporation.

TROUBLESHOOTING

- | | |
|---------------------------------------|---|
| Unloader cycles | <ul style="list-style-type: none"> ● Worn O-ring or check valve ● Fitting leaking downstream ● O-ring in gun worn |
| Liquid leaking from bottom | <ul style="list-style-type: none"> ● O-ring for seat or inlet fitting cut or worn |
| Liquid leaking from middle | <ul style="list-style-type: none"> ● O-ring for piston worn or cut |
| Unloader will not come up to pressure | <ul style="list-style-type: none"> ● Not properly sized for system pressure ● Foreign material in unloader ● Piston o-rings worn ● Nozzle worn ● Jam nuts not properly set |
| Extreme pressure spikes | <ul style="list-style-type: none"> ● Adjusting handle turned completely into unloader ● Restricted by-pass or no by-pass ● System flow exceeds unloader rating |

Approximate Pressure Reading at Gauge	Gauge Between Pump/Unloader	Gauge Between Unloader/Gun-Nozzle-Valve
System in operation (gun open)	system pressure	system pressure
System in by-pass (gun closed)	low pressure 0-150 PSI	system pressure +200 PSI

90 DAY WARRANTY

Refer to complete CAT PUMPS Warranty for further information.

EXPLODED VIEW

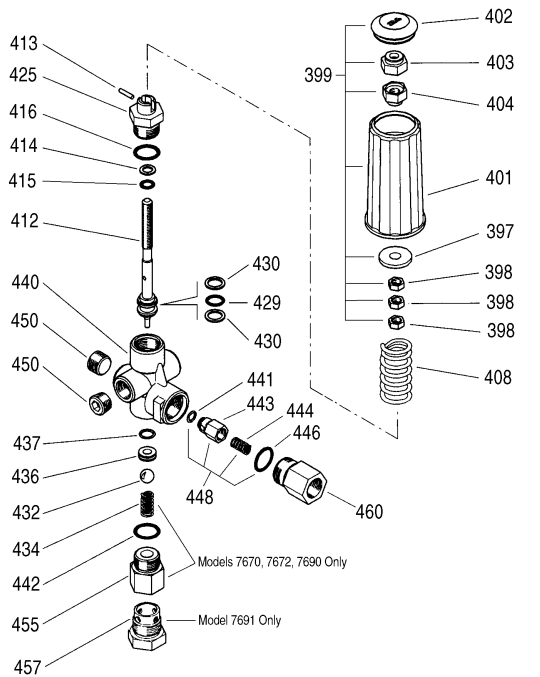

CUTAWAY

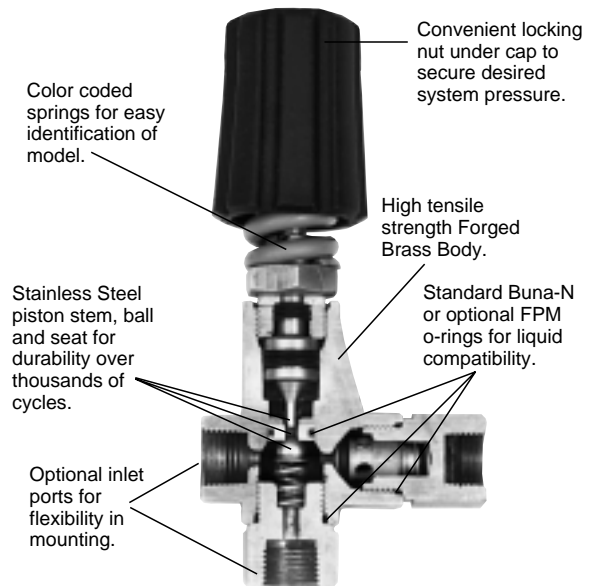

PARTS LIST

ITEM	DESCRIPTION	MODEL NUMBER				QTY
		7670 MATL	7672 MATL	7690 MATL	7691 MATL	
397	Washer, Flat	— STL	— STL	— STL	— STL	1
398	Nut, Jam (M8x1.25)	32116 BB	32116 BB	32116 BB	32116 BB	3
399	Handle, Adjusting, Assembly (Incls: 397, 398, 401, 402, 403, 404)	31395 NY	31395 NY	31395 NY	31395 NY	1
401	Handle, Adjusting	31284 NY	31284 NY	31395 NY	31395 NY	1
402	Cap, Handle	31286 NY	31286 NY	31286 NY	31286 NY	1
403	Nut, Hex, NyLock (M8)	32811 STZP	32811 STZP	32811 STZP	32811 STZP	1
404	Nut, Adjust (M8)	— BB	— BB	— BB	— BB	1
408	Spring, White (1750 PSI)	32090 STL	—	—	—	1
	Spring, Blue (3450 PSI)	—	32092 STL	32092 STL	32092 STL	1
412	Stem, Piston	33219 S	33219 S	33219 S	33219 S	1
413	Pin, Piston, Lock	32818 S	32818 S	32818 S	32818 S	1
414	Back-up-Ring, Piston Stem	32873 PTFE	32873 PTFE	32873 PTFE	32873 PTFE	1
415	O-Ring, Piston Stem	— NBR/FPM	— NBR/FPM	— NBR/FPM	— NBR/FPM	1
416	O-Ring, Retainer	— NBR/FPM	— NBR/FPM	— NBR/FPM	— NBR/FPM	1
425	Retainer, Piston	33318 BB	33318 BB	33318 BB	33318 BB	1
429	O-Ring, Piston	— NBR/FPM	— NBR/FPM	— NBR/FPM	— NBR/FPM	1
430	Back-up-Ring, Piston	33303 PTFE	33303 PTFE	33303 PTFE	33303 PTFE	2
432	Ball	32289 SSSS	32289 SSSS	31075 SSSS	31075 SSSS	1
434	Spring	— STZP	— STZP	— STZP	—	1
436	Seat, w/O-Ring	— NBR	— NBR	33806 NBR	33806 NBR	1
437	O-Ring, Seat - 85D	— NBR/FPM	— NBR/FPM	— NBR/FPM	— NBR/FPM	1
440	Body	— FBB	— FBB	— FBB	— FBB	1
441	O-Ring, Check Valve	— NBR/FPM	— NBR/FPM	— NBR/FPM	— NBR/FPM	1
442	O-Ring, Inlet Fitting	— NBR/FPM	— NBR/FPM	— NBR/FPM	— NBR/FPM	1
443	Valve, Check	33852 BB	33852 BB	33852 BB	33852 BB	1
444	Spring, Check Valve	33843 S	33843 S	33843 S	33843 S	1
446	O-Ring, Discharge Fitting	— NBR/FPM	— NBR/FPM	— NBR/FPM	— NBR/FPM	1
448	Kit, Check Valve (Incls: 441, 443, 444, 446)	31370 NBR	31370 NBR	31371 BB	31371 BB	1
450	Plug, Inlet (3/8" NPTM)	46690 BB	46690 BB	46690 BB	46690 BB	1
455	Fitting, Inlet (3/8" NPTF)	32111 BB	32111 BB	31211 BB	—	1
457	Plug, Quick Start	—	—	—	— BB	1
458	Kit, Valve (Incls: 432, 434, 436, 442)	33147 NBR	33147 NBR	31147 NBR	—	1
460	Fitting, Discharge (3/8" NPTF)	33855 BB	33855 BB	33855 BB	33855 BB	1
468	Kit, O-Ring (Incls: 414, 415, 416, 429, 430, 437, 441, 442, 446)	31365 NBR	31365 NBR	31366 NBR	31366 NBR	1
	Kit, O-Ring (Incls: 414, 415, 416, 429, 430, 437, 441, 442, 446)	31375 FPM	31375 FPM	31375 FPM	31375 FPM	1

Bold print part numbers are unique to a particular model. Italics are optional items.

MATERIAL CODES (Not Part of Part Number): BB=Brass FPM=Fluorocarbon NBR=Medium Nitrile (Buna-N)
 NY=Nylon PTFE=Pure Polytetrafluoroethylene S=304SS SSSS=440SS STL=Steel STZP=Steel/Zinc Plated

Products described hereon are covered by one or more of the following U.S. patents 3558244, 3652188, 3809508, 3920356, 3930756 and 5035580

World Headquarters

CAT PUMPS

1681 - 94th Lane N.E. Minneapolis, MN 55449-4324

Phone (763) 780-5440 — FAX (763) 780-2958

e-mail: techsupport@catpumps.com

www.catpumps.com

International Inquiries

FAX (763) 785-4329

e-mail: intlsales@catpumps.com



The Pumps with Nine Lives

CAT PUMPS (U.K.) LTD.

1 Fleet Business Park, Sandy Lane, Church Crookham
 FLEET, Hampshire, GU52 8BF, England
 Phone Fleet 44 1252-622031 — Fax 44 1252-626655
 e-mail: sales@catpumps.co.uk www.catpumps.co.uk

N.V. CAT PUMPS INTERNATIONAL S.A.

Heiveldekens 6A, B-2550 Kontich, Belgium
 Phone 32-3-450.71.50 — Fax 32-3-450.71.51
 e-mail: cpi@catpumps.be www.catpumps.be

CAT PUMPS DEUTSCHLAND GmbH

Buchwiese 2, D-65510 Idstein, Germany
 Phone 49 6126-9303 0 — Fax 49 6126-9303 33
 e-mail: catpumps@t-online.de www.catpumps.de