



Model 7730

Model 7850

Modular Pressure Sensitive Regulating Unloader

Model 7730

*With Handle and Fixed Chemical Injector
Use with Pump Model 3CP*

Model 7850

*With Handle and Fixed Chemical Injector
Use with Pump Model 5CP (Except Model 5CP6120)*

FEATURES

- Provides system pressure setting and protection for single pump and non-weep gun installation.
- Built-in by-pass channel for safe low pressure by-pass when gun is shut off.
- Convenient flo-thru screws for easy direct mounting.
- Pressure sensitive feature permits immediate pressure when gun opens.
- Handle permits easy adjustments of pressure.

SPECIFICATIONS

	U.S. Measure	Metric Measure
MODEL 7730		
Flow Range	0.5-4.5 GPM	(1.9-17 L/M)
Pressure Range	100-3000 PSI	(7-210 BAR)
Weight	1.76 lbs.	(0.80 kg)
Dimensions	6.50 x 3.88 x 1.62"	(165 x 98.5 x 41 mm)

MODEL 7850		
Flow Range	0.5-6.0 GPM	(1.9-23 L/M)
Pressure Range	100-4000 PSI	(7-275 BAR)
Weight	2.21 lbs.	(1.00 kg)
Dimensions	7.0 x 4.0 x 1.62"	(178 x 101.6 x 41 mm)

COMMON SPECIFICATIONS

Maximum Temperature	160°F	(71°C)
Inlet Port (1)	1/2" NPTF	(1/2" NPTF)
Outlet Port (1)	3/8" NPTM	(3/8" NPTM)
By-Pass Port	Built-in Channel	(Built-in Channel)

⚠ WARNING

All systems require both a primary pressure regulating device (i.e., regulator, unloader) and a secondary pressure safety relief device (i.e., pop-off valve, safety valve). Failure to install such relief devices could result in personal injury or damage to the pump or to system components. CAT PUMPS does not assume any liability or responsibility for the operation of a customer's high pressure system.

90 DAY WARRANTY

Refer to complete CAT PUMPS Warranty for further information.

“Customer confidence is our greatest asset”

SELECTION

These are pressure sensitive regulating unloaders. They are designed for systems with a single pump, solenoid (gate) valve, nozzle and standard gun. "Weep" guns are not recommended with these unloaders.

Note: For multiple pump systems, it is best to use a pressure regulator not a pressure sensitive regulating unloader.

These pressure sensitive regulating unloaders should meet both the desired system flow (combined nozzle flow rate requirement) and the desired system pressure.

Note: Operation below the minimum flow of the unloader causes the unloader to cycle. Operation above the maximum flows of the unloader causes premature unloader wear, cycling and prevents attaining desired system pressure.

INSTALLATION

These pressure sensitive regulating unloaders mount directly to the side inlet and discharge ports of the 3CP and 5CP plunger pumps. The unloaders are held in place by one 1/2" NPTM flo-thru screw on the bottom and one 3/8" NPTM flo-thru screw at the top.

Note: There are two seal washers for each port size. One seal washer is mounted between pump manifold and unloader body and the other is located between unloader body and under the head of the flo-thru screw.

The inlet connection of these unloaders have a 1/2" NPTF sized port and is located on the bottom. There is an arrow cast into the body indicating the direction of flow. The water supply is connected here.

The discharge connection of these unloaders with the chemical injector installed is a 3/8" NPTM sized port. An arrow with the word OUT is cast into the body indicating the direction of flow. Without the chemical injector the unloader port size is M18. Plumbing for the spray gun, solenoid (gate) valve or nozzle is connected here.

There is no by-pass connection for these unloaders; these unloaders have a built-in channel for internal by-pass.

OPERATION

These pressure sensitive regulating unloaders holds established system pressure in the discharge line when the trigger gun is closed or solenoid (gate) valve is closed or the nozzle is clogged; thus by-passing all unrequired flow. Squeezing the trigger gun or opening the solenoid (gate) valve will close off the by-pass and return to established system pressure without delay.

PRESSURE ADJUSTMENT

1. Setting and adjusting the unloader pressure must be done with the system "on".
 2. Start the system with unloader backed off to the lowest pressure setting (counterclockwise direction).
 3. Squeeze the trigger and read the pressure on the gauge at the pump.
- Note:** Do not read the pressure at the gun or nozzle.
4. If more pressure is desired, release the trigger, turn adjusting cap one quarter turn in clockwise direction.
 5. Squeeze the trigger and read the pressure.
 6. Repeat this process until desired system pressure is attained.
 7. Once the desired system pressure is reached, stop turning the adjusting cap.
 8. Thread locking nut up to adjusting cap and tighten setscrew.

Note: Locking nut is not set at the factory.

CAUTION: A minimum by-pass flow of 5% of the unloader rated flow capacity is required for proper unloader performance. If the entire output is directed through the unloader (zero by-pass) the "cushioning" feature of the by-pass liquid is eliminated and the unloader can malfunction or wear prematurely.

9. If desired system pressure cannot be reached, review TROUBLESHOOTING chart.
10. When servicing existing systems, loosen setscrew and back locking nut away from adjusting cap.
11. Follow adjustment procedures as stated above for new unloaders.

Note: Do not adjust unloader pressure setting to compensate for a worn nozzle. Check the nozzle as part of the regular maintenance and replace if worn.

TYPICAL PRESSURE CLEANING INSTALLATION

3CP or 5CP Plunger Pump

- 1 Pressure Gauge
- 2 Pop-off Valve
- 3 Fixed Chemical Injector
- 4 Garden Hose Fitting (3/4" GHF x 1/2" NPTM)
- 5 Pressure Sensitive Regulating Unloader
- 6 1/2" NPTM Flo-Thru Screw
- 7 3/8" NPTM Flo-Thru Screw
- 8 Black Pressure Adjusting Handle
- 9 Triplex Plunger Pump

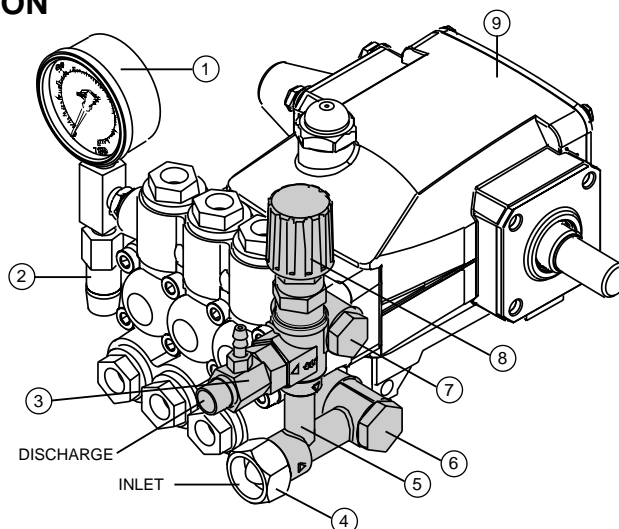

SERVICING

CAUTION: Before commencing with service, shut off drive (electric motor, gas or diesel engine) and turn off water supply to pump. Relieve all discharge line pressure by triggering gun or opening valve in discharge line.

Disassembly

1. Disconnect inlet and discharge plumbing from unloader.
2. Remove unloader from pump by unthreading inlet and discharge flo-thru screws.
3. Remove black adjusting handle.
4. Loosen M4 set screw on locking nut and turn locking nut in a clockwise direction away from brass adjusting cap.
5. Remove brass adjusting cap by turning in a counterclockwise direction.
6. Remove locking nut.
7. Pull exposed spring and flat spring retainer from unloader body. Examine spring for fatigue or breaks and replace as needed.
8. Using a wrench, unthread piston retainer with o-ring from unloader body. Examine o-ring for cuts or wear and replace as needed.

Note: The piston stem and valve/ball assembly will either come out as one assembly when removing the piston retainer or will remain in unloader body.

9. Unthread the piston stem from valve/ball assembly by securing valve/ball assembly with pliers and placing screwdriver into slotted head of piston stem. On model 7730, remove washer and valve retainer with o-rings. On model 7850, remove washer and valve retainer with o-rings and back-up-rings.

CAUTION: Exercise extreme caution to avoid contact and damage to the tapered surface of the valve/ball.

10. Remove seat with attached o-ring from unloader body. Examine seat for grooves, pitting or wear and replace as needed. Examine o-ring for cuts or wear and replace as needed.
11. Unthread chemical injector from unloader body.
12. Remove o-ring, check valve with o-ring and spring. Examine check valve and spring for fatigue and wear and replace as needed. Examine o-rings for cuts or wear and replace as needed.

Reassembly

1. Before installing chemical injector, inspect sealing area where the check valve makes contact within the internal body of the unloader for grooves, pitting and wear. If unloader surface is damaged, stop the repair and discard unloader and install complete new unloader onto pump. If not, proceed with step 2.
2. Place spring on end of check valve without o-ring. Install assembly into chemical injector.
3. Apply Loctite® 609 to threads of chemical injector. Thread chemical injector into body of unloader.
4. Lubricate and press seat with o-ring into unloader body.
5. Lubricate and install o-ring over slotted head of piston stem, then position back-up-ring on top of o-ring.
6. Lubricate and install larger o-ring around outside diameter of valve retainer and smaller o-ring on the inside diameter of valve retainer. On the model 7850 install back-up-ring below o-ring on inside diameter of valve retainer.
7. Place washer, then valve retainer with o-rings onto piston stem. Apply Loctite® 242® to threads of piston stem and screw into valve/ball assembly.
8. Insert complete piston stem and valve/ball assembly into unloader chamber with valve/ball assembly facing down and slotted head of piston stem facing up.
9. Apply Loctite® 609 to threads of piston retainer and hand thread into unloader body. Then tighten with wrench.
10. Place flat spring retainer on top of piston stem head and then install spring.
11. Thread locking nut and brass adjusting cap onto retainer.
12. Reinstall M4 set screw, but do not tighten until system pressure is set.
13. Place black adjusting handle over brass adjusting cap.
14. Re-install unloader onto pump by using 3/8" and 1/2" flo-thru screws and seal washers.
15. Reconnect inlet and discharge plumbing to unloader.
16. Proceed to PRESSURE ADJUSTMENT to set system pressure.

Loctite® and 242® are registered trademarks of the Henkel Corporation.

7345 CHEMICAL INJECTOR PERFORMANCE CHART

Unloader Model	Desired Pump Flow	Injector Orifice Size	Maximum Injecting Pressure	Maximum Chemical Draw	Pressure Drop Across Injector At System Pressure (3000 PSI)
7730	3.0	2.1	163 PSI	35.5 oz/min	200 PSI
7730	3.5	2.1	200 PSI	45.6 oz/min	258 PSI

Unloader Model	Desired Pump Flow	Injector Orifice Size	Maximum Injecting Pressure	Maximum Chemical Draw	Pressure Drop Across Injector At System Pressure (4000 PSI)
7850	3.0	2.1	190 PSI	70.0 oz/min	136 PSI
7850	3.5	2.1	260 PSI	74.2 oz/min	245 PSI
7850	4.0	2.1	358 PSI	76.8 oz/min	288 PSI

Optimum performance of chemical injector occurs with a 35 ft. high pressure hose and a minimum 3/8" I.D. The type of hose, extended lengths, reduced I.D. and fittings may create back pressures in excess of the low pressure nozzle rating and prevent the injector from drawing chemical. See Hose Friction Loss Chart in Service Manual. **Deduct hose friction loss from above low PSI Nozzle. Consult CAT PUMPS for assistance with other options.**

CAUTION: Deduct the pressure drop shown in the performance chart from your desired system pressure to arrive at the maximum high pressure nozzle rating. This is essential to avoid over-pressurizing the pump.

TROUBLESHOOTING

Unloader cycles	<ul style="list-style-type: none"> ● Worn O-Ring or check valve ● Fitting leaking downstream ● O-Ring in gun worn
Liquid leaking from bottom	<ul style="list-style-type: none"> ● O-Ring for seat or inlet fitting seal washer cut or worn
Unloader will not come up to pressure	<ul style="list-style-type: none"> ● Unloader not properly sized for system ● Foreign material in unloader ● Piston or retainer o-rings worn or cut ● Nozzle worn ● Nozzle not properly sized for system
Extreme pressure spikes	<ul style="list-style-type: none"> ● Adjusting cap turned completely into unloader ● Restricted by-pass or no by-pass ● System flow exceeds unloader rating ● Locking nut not properly set

EXPLODED VIEW 7730 Unloader

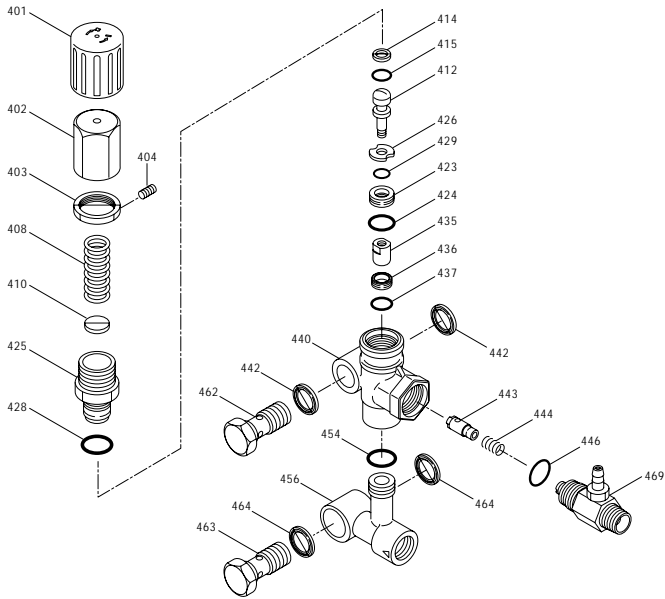

PARTS LIST

ITEM	P/N	MATL	DESCRIPTION	QTY.
401	547797	NY	Handle, Adjusting (Black)	1
402	547798	BB	Cap, Adjusting	1
403	548671	BB	Nut, Lock (M18x1)	1
404	88953	S	Screw, Set (M4x4)	1
408	32094	STZP R	Spring, Pressure	1
410	45862	STZP	Retainer, Spring	1
	549352	STCP R	Retainer, Spring	1
412	45694	S	Stem, Piston (M5)	1
414	20184	PTFE	Back-up-Ring, Piston Stem	1
415	14190	NBR	O-Ring, Piston Stem - 70D	1
423	46249	BB	Retainer, Valve	1
425	547799	BB	Retainer, Piston	1
424	13966	NBR	O-Ring, Valve Retainer - 70D	1
426	46250	S	Washer	1
428	26133	NBR	O-Ring, Piston Retainer - 80D	1
429	17399	NBR	O-Ring, Valve Retainer - 80D	1
435	547800	S	Valve/Ball Assembly	1
436	548673	S	Seat	1
437	13963	NBR	O-Ring, Seat - 70D	1
440	—	FBB	Body	1
442	49121	STL	Washer, Seal (3/8")	2
443	49245	BB	Valve, Check w/NBR O-Ring	1
444	117275	S	Spring, Check Valve	1
446	26133	NBR	O-Ring, Body - 80D	1
454	11346	NBR	O-Ring, Manifold - 70D	1
456	—	BB	Manifold, Lower Body	1
460	126724	BB	Fitting, Discharge (3/8" NPTF) Not Shown	1
462	49120	BB	Screw, Flo-Thru (3/8" NPTM)	1
463	49117	BB	Screw, Flo-Thru (1/2" NPTM)	1
464	49118	STL	Washer, Seal 1/2"	2
468	31808	NBR	Kit, O-Ring (Incls: 414, 415, 424, 428, 429, 437, 454, 482)	1
469	7345	BB	Injector, Chemical Fixed (M18x1)	1

Italics are optional items. R Components comply with RoHS Directive.
 MATERIAL CODES (Not Part of Part Number): BB=Brass FBB=Forged Brass
 NBR=Medium Nitrile (Buna-N) NY=Nylon PTFE=Pure Polytetrafluoroethylene
 S=304SS STL=Steel STCP=Steel/Chrome Plated STZP=Steel/Zinc Plated

EXPLODED VIEW 7850 Unloader

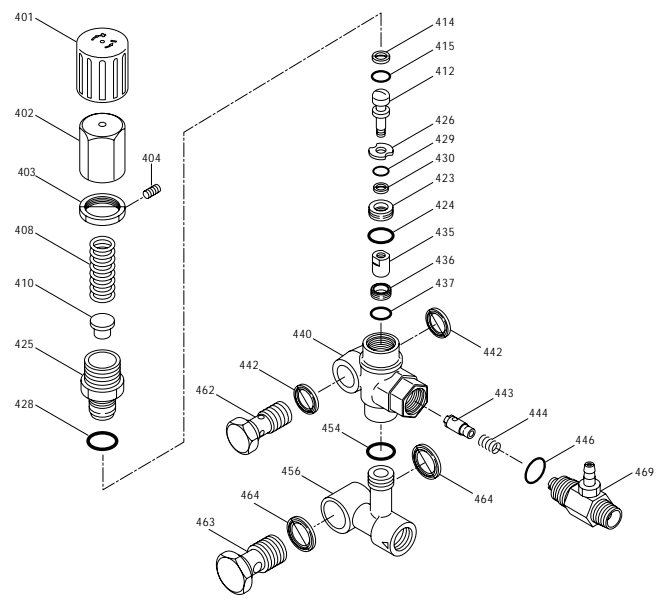

PARTS LIST

ITEM	P/N	MATL	DESCRIPTION	QTY.
401	49100	NY	Handle, Adjusting (Black)	1
402	49099	BB	Cap, Adjusting	1
403	125521	BB	Nut, Locking (M25x1)	1
404	88953	S	Screw, Set (M4x4)	1
408	45198	ZP	Spring, Pressure	1
410	49101	STZP	Retainer, Spring	1
412	49103	S	Stem, Piston	1
414	20889	PTFE	Back-up-Ring, Piston Stem	1
415	49104	NBR	O-Ring, Piston Stem - 90D	1
423	49105	BB	Retainer, Valve	1
424	49106	NBR	O-Ring, Valve Retainer - 70D	1
425	49102	BB	Retainer, Piston	1
426	49107	S	Washer	1
428	26133	NBR	O-Ring, Piston Retainer - 80D	1
429	22056	NBR	O-Ring, Valve Retainer - 70D	1
430	49123	D	Back-up-Ring, Valve Retainer	1
435	49108	S	Valve/Ball Assembly	1
436	49257	S	Seat	1
437	13965	NBR	O-Ring, Seat - 70D	1
440	—	FBB	Body	1
442	49121	STL	Washer, Seal (3/8")	2
443	49245	BB	Valve, Check w/NBR O-Ring	1
444	117275	S	Spring, Check Valve	1
446	26133	NBR	O-Ring, Body - 80D	1
454	11346	NBR	O-Ring, Manifold - 70D	1
456	—	BB	Manifold, Lower Body	1
460	126724	BB	Fitting, Discharge (3/8" NPTF) Not Shown	1
462	49120	BB	Screw, Flo-Thru (3/8" NPTM)	1
463	49117	BB	Screw, Flo-Thru (1/2" NPTM)	1
464	49118	STL	Washer, Seal (1/2")	2
468	31708	NBR	Kit, O-Ring (Incls: 414, 415, 424, 428, 429, 430, 437, 454, 482)	1
469	7345	BB	Injector, Chemical Fixed (M18x1)	1

Italics are optional items. R Components comply with RoHS Directive.
 MATERIAL CODES (Not Part of Part Number): BB=Brass D=Acetal
 FBB=Forged Brass NBR=Medium Nitrile (Buna-N) NY=Nylon
 PTFE=Pure Polytetrafluoroethylene S=304SS STL=Steel
 STZP=Steel/Zinc Plated ZP=Zinc Plated

Products described hereon are covered by one or more of the following U.S. patents 3558244, 3652188, 3809508, 3920356, 3930756 and 5035580

World Headquarters
CAT PUMPS
 1681 - 94th Lane N.E. Minneapolis, MN 55449-4324
 Phone (763) 780-5440 — FAX (763) 780-2958
 e-mail: techsupport@catpumps.com
 www.catpumps.com



CAT PUMPS (U.K.) LTD.
 1 Fleet Business Park, Sandy Lane, Church Crookham
 FLEET, Hampshire, GU52 8BF, England
 Phone Fleet 44 1252-622031 — Fax 44 1252-626655
 e-mail: sales@catpumps.co.uk
N.V. CAT PUMPS INTERNATIONAL S.A.
 Heiveldeken 6A, B-2550 Kontich, Belgium
 Phone 32-3-450.71.50 — Fax 32-3-450.71.51
 e-mail: cpi@catpumps.be www.catpumps.be
CAT PUMPS DEUTSCHLAND GmbH
 Buchwiese 2, D-65510 Idstein, Germany
 Phone 49 6126-9303 0 — Fax 49 6126-9303 33
 e-mail: catpumps@t-online.de www.catpumps.de

International Inquiries
 FAX (763) 785-4329
 e-mail: intlsales@catpumps.com