

Electric motor or gas engine must be purchased separately.

## FEATURES

- Triplex plunger design provides a smooth liquid flow.
- Specially formulated Hi-Pressure Seals and concentric solid ceramic plungers assure true wear surface and extended seal life.
- Ultimate compact, direct-drive unit for maximum portability.
- Integral Regulating Unloader with built-in by-pass standard on all units to assure system pressure control and pump protection.
- Fixed chemical injector standard on all units offers cleaning flexibility.
- Stacked valve design for ease in servicing.
- Swivel garden hose fitting with filter screen for easy inlet connection.

### **⚠ WARNING**

All systems require both a primary pressure regulating device (i.e., regulator, unloader) and a secondary pressure safety relief device (i.e., pop-off valve, safety valve). Failure to install such relief devices could result in personal injury or damage to the pump or to system components. CAT PUMPS does not assume any liability or responsibility for the operation of a customer's high pressure system.

## Direct-Drive Plunger Pumps

**Electric Model**      **2DX20ES**  
**Gas Model**            **2DX30GS**

### SPECIFICATIONS

U.S. Measure      Metric Measure

#### MODEL 2DX20ES

Flow .....2.0 GPM (7.6 L/M)  
 Max. Discharge Pressure .....2000 PSI (140 BAR)  
 RPM .....3450 RPM (3450 RPM)  
 Stroke .....0.157" (4.0 mm)  
 Shaft Diameter.....5/8" (15.8 mm)

#### MODEL 2DX30GS

Flow .....3.1 GPM (11.7 L/M)  
 Max. Discharge Pressure .....2000 PSI (140 BAR)  
 RPM .....3450 RPM (3450 RPM)  
 Stroke .....0.244" (6.2 mm)  
 Shaft Diameter.....3/4" (19.0 mm)

### COMMON SPECIFICATIONS

Inlet Pressure Range.....Flooded to 60 PSI (Flooded to 4 Bar)  
 Bore .....0.630" (16 mm)  
 Max. Liquid Temperature .....140°F (60°C)  
 Above 130°F call CAT PUMPS for inlet conditions and elastomer recommendations.  
 Crankcase Capacity.....8.5 oz. (0.25 L)  
 Inlet Ports (1) .....3/4" GH (3/4" GH)  
 Discharge Port (1) .....3/8" NPTM (3/8" NPTM)  
 Chemical Injection Barb .....8/32" UNF (8/32" UNF)  
 Weight .....10.7 lbs. (4.9 kg)  
 Dimensions .....7.99 x 7.75 x 6.29" (203 x 197 x 160 mm)

### ELECTRIC HORSEPOWER REQUIREMENTS

MODEL	FLOW		PRESSURE				RPM
			PSI 1000	PSI 1200	PSI 1500	PSI 2000	
	U.S. GPM	L/M	BAR 70	BAR 85	BAR 105	BAR 140	
2DX20ES	2.0	7.6	1.37	1.64	2.05	2.74	3450
2DX30GS	3.1	11.7	2.12	2.55	3.18	4.25	3450

**DETERMINING THE PUMP R.P.M.**       $\frac{\text{Rated G.P.M.}}{\text{Rated R.P.M.}}$       =       $\frac{\text{"Desired" G.P.M.}}{\text{"Desired" R.P.M.}}$

**DETERMINING THE REQUIRED H.P.**       $\frac{\text{GPM} \times \text{PSI}}{1460}$       =      Electric Brake H. P. Required

**DETERMINING MOTOR PULLEY SIZE**       $\frac{\text{Motor Pulley O.D.}}{\text{Pump R.P.M.}}$       =       $\frac{\text{Pump Pulley O.D.}}{\text{Motor R.P.M.}}$

Note: Consult engine manufacturer when using gas or diesel engine. Refer to pump Service Manual for repair procedure, additional technical information and pump warranty.

*"Customer confidence is our greatest asset"*

# EXPLODED VIEW

February 2008

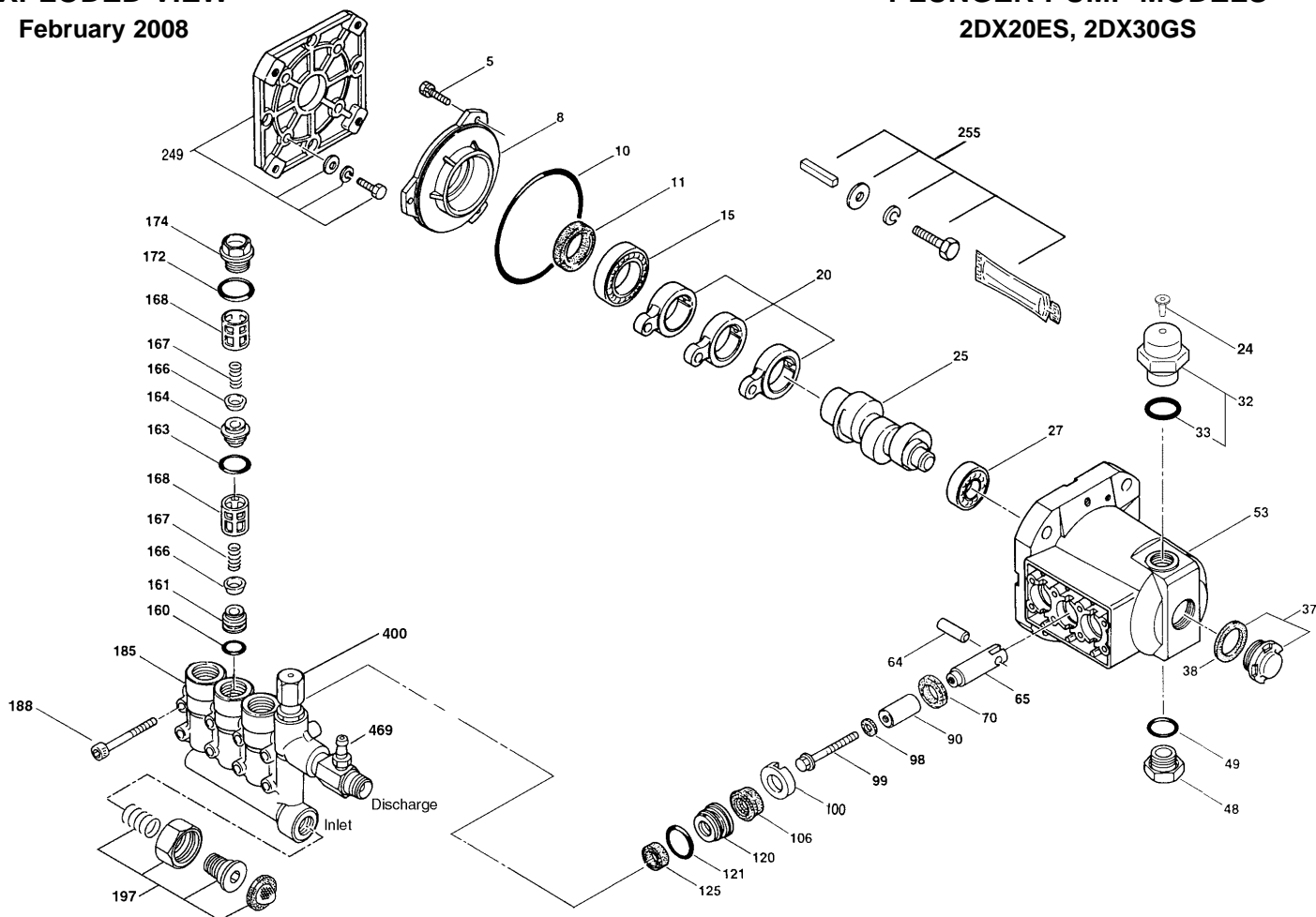

# PLUNGER PUMP MODELS

2DX20ES, 2DX30GS

## PARTS LIST

ITEM	PN	MATL	DESCRIPTION	QTY	ITEM	P/N	MATL	DESCRIPTION	QTY
5	547161	STCP	Screw, HH (M6x14) [04/05]	3	166	46764	S	Valve	6
	<i>549360</i>	<i>STCP R</i>	<i>Screw, HH (M6x14) [04/05]</i>	3	167	46865	S	Spring	6
8	547153	AL	Cover, Bearing [04/05]	1	168	543988	PVDF	Retainer, Spring	6
10	14041	NBR	O-Ring, Bearing Cover - 70D	1	172	142807	NBR	O-Ring, Plug - 90D	3
11	55337	NBR	Seal, Oil - 70D	1	174	46759	BB	Plug, Valve (M20x1.5)	3
15	14488	STL	Bearing, Ball	1		35759	BB	Plug, Valve w/1/4" NPT Port	1
20	547048	TNM	Rod, Connecting	3	185	† 548592	BB	Head, Manifold w/Integral Unloader Body	1
24	76045	LDPE	Plug, Oil Cap (Remove Before Startup)	1	188	542406	STZP	Screw, HSH (M6x60)	8
25	<b>545765</b>	CM	Crankshaft, 3450 RPM, 5/8", 4.0 mm, 20ES	1		549357	STCP R	Screw, HSH (M6x60)	8
	<b>543295</b>	CM	Crankshaft, 3450 RPM, 3/4", 6.2 mm, 30GS	1	197	941516	BB	Assy, GH, 3/8" NPTM	1
27	13832	STL	Bearing, Ball	1		—	—	Nut, Swivel (3/4" FGH)	1
32	547961	RTP	Cap, Oil Filler w/O-Ring [01/04]	1		—	—	Fitting (3/8" NPTM)	1
33	14179	NBR	O-Ring, Oil Filler Cap - 70D	1		—	—	Screen, Inlet	1
37	92241	—	Gauge, Bubble Oil w/Gasket	1		—	—	Spring	1
38	44428	NBR	Gasket, Flat Flex, Oil Gauge - 80D	1	249	30520	—	Assy, Adapter Mount, Standard, GAS	1
48	44842	NY	Plug, Drain	1		46271	AL	Flange, Adapter	1
49	14179	NBR	O-Ring, Drain Plug - 70D	1		549351	STCP R	Screw, HH (5/16"-24UNFx20)	4
53	542407	AL	Crankcase [02/05]	1		15845	STZP	Lockwasher (M8)	4
64	46229	CM	Pin, Crosshead	3		126232	STCP R	Lockwasher (M8)	4
65	542402	BB	Rod, Plunger	3		126573	STCP R	Washer, Flat (M8)	4
70	47215	NBR	Seal, Oil - 70D	3	255	30516	STZP R	Assy, Bolt Mount, ELECTRIC/GAS	1
90	542403	CC	Plunger (M16x27)	3		34100	STZP	Screw, HH (3/8"-16UNCx1-3/8")	4
98	46730	NBR	Washer, Seal - 90D	3		126543	STCP R	Screw, HH (3/8"-16UNCx1-3/8")	4
99	542405	S	Retainer, Plunger (M6x35)	3		30980	STZP R	Washer, Flat (3/8")	4
100	46233	NY	Retainer, Seal	3		127024	STZP R	Washer, Flat (3/8")	4
106	48222	NBR	Seal, LPS w/S-Spg - 85D	3		30921	STZP R	Lockwasher (3/8")	4
120	547357	BB	Case, Seal [02/03]	3		127025	STZP R	Lockwasher (3/8")	4
121	13976	NBR	O-Ring, Seal Case - 70D	3		6106	—	Lubricant, Antiseize	1
125	46240	NBR	Seal, HPS w/S	3		34050	STL	Key (3/16x3/16x27 HD)	1
160	13965	NBR	O-Ring, Seat, Inlet - 70D	3	300	33053	NBR	Kit, Seal (Incls: 98, 106, 121, 125)	1
161	545177	S	Seat, Inlet	3	310	33057	NBR	Kit, Valve (Incls: 160, 161, 163, 164, 166, 167, 168, 172)	1
163	19285	NBR	O-Ring, Seat, Discharge - 70D	3	400	—	—	Unloader, Integral (See Individual Parts)	1
164	545178	S	Seat, Discharge	3	469	—	—	Injector, Chemical	1

*Italics are optional items.* [ ] Date of latest production change. † Production parts are different than repair parts. R Components comply with RoHS Directive.

See Tech Bulletins 002, 024, 036, 043, 055, 074, 083, 086 and 094 for additional information.

MATERIAL CODES (Not Part of Part Number): AL=Aluminum BB=Brass CC=Ceramic CM=Chrome-moly

NBR=Medium Nitrile (Buna-N) NY=Nylon PVDF=Polyvinylidene Fluoride RTP=Reinforced Composite S=304SS STL=Steel

STCP=Steel/Chrome Plated STZP=Steel/Zinc Plated TNM=Special High Strength

NOTE: Discard Key which may come standard with most motors and engines and **use only the key included in this kit.**

Center raised pilot guide on the **Adapter Plate** assures proper alignment of pump and engine. Before mounting pump onto engine inspect engine for **recessed seal and bearing guide** to permit adapter to completely seat into recess and four bosses to be flush with engine face.

# INTEGRAL UNLOADER

## SPECIFICATIONS

	<b>U.S. Measure</b>	<b>Metric Measure</b>
Flow.....	3.1 GPM	(11.7 L/M)
PSI Range.....	100-2000 PSI	(7-140 BAR)
Inlet Port .....	3/4" GHF	(3/4" GHF)
Discharge Port .....	M18x1.0	(M18x1.0)

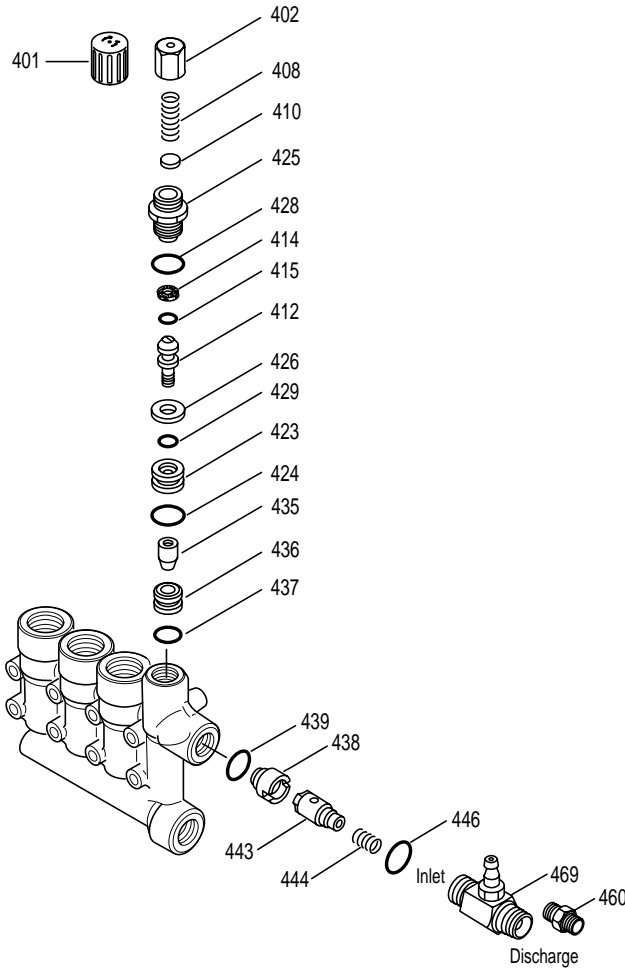

## PARTS LIST

ITEM	PN	MATL	DESCRIPTION	QTY.
401	32088	NY	Handle, Adjustable	1
402	46570	BB	Cap, Adjusting	1
408	33394	STZP R	Spring, Pressure	1
410	549352	STCP	Retainer, Spring	1
412	46251	BB	Stem, Piston	1
—	548229	BB	Assy, Piston	1
414	28338	PTFE	Back-up-Ring, Piston Stem	1
415	22056	NBR	O-Ring, Piston Stem - 70D	1
423	46249	BB	Retainer, Valve	1
424	13966	NBR	O-Ring, Valve Retainer (Outer) - 70D	1
425	46248	BB	Retainer, Piston	1
426	46250	S	Washer	1
428	13969	NBR	O-Ring, Piston Retainer - 70D	1
429	17399	NBR	O-Ring, Valve Retainer (Inner) - 80D	1
435	548193	S	Valve	1
436	46253	S	Seat	1
437	13963	NBR	O-Ring, Seat - 70D	1
439	13963	NBR	O-Ring, Seat, Check Valve - 70D	1
438	46254	NY	Seat, Check Valve	1
443	541060	BB	Valve, Check w/O-Ring	1
444	45924	S	Spring	1
446	13969	NBR	O-Ring, Body - 70D	1
460	107681	BB	Fitting, Discharge (3/8" NPTM)	1
468	33099	NBR	Kit, O-Ring (Incls: 414,415,428,429,431,441)	1
—	31088	NBR	Kit, Repair (Incls: 412,431,436,441)	1
469	7231	BB	Injector, Chemical Fixed, 2DX20ES	1
	7232	BB	Injector, Chemical Fixed, 2DX30GS	1

*Italics are optional items. R Components comply with RoHS Directive.*

NOTE: If check valve is removed, unloader becomes a regulator.

MATERIAL CODES (Not Part of Part Number): BB=Brass NBR=Medium Nitrile (Buna-N) NY=Nylon PTFE=Pure Polytetrafluoroethylene S=304SS STCP=Steel/Chrome Plated STZP=Steel/Zinc Plated

# UNLOADER TYPE

An integral unloader with built-in by-pass is part of the discharge manifold to provide system pressure regulation and pump protection. This pump also includes a fixed chemical injector for chemical application.

## OPERATION:

Pump should be purged of air before commencing with operation. Liquid must flow through the pump without discharge restriction to assure full system pressure is reached

Install a pressure gauge close to the manifold head of the pump to assist in setting system pressure and to periodically monitor system pressure.

Setting and adjusting the unloader pressure must be done with the system turned on. Start the system with the unloader backed off to the lowest pressure setting (counterclockwise direction). Squeeze the trigger and read the pressure on the gauge at the pump. Do not read pressure at the gun or nozzle. If more pressure is desired, release the trigger, turn adjusting cap one quarter turn in a clockwise direction. Squeeze the trigger and read the pressure. Repeat this process until the desired system pressure is reached.

**NOTE:** Pressure is not set at the factory.

## SERVICE:

The unloader should be serviced on the same schedule as the seals in the pump. Refer to 2DX Service Manual for start-up, servicing of seals and valves, torque requirements and diagnosis and maintenance chart.

# FIXED CHEMICAL INJECTOR

## SPECIFICATIONS

	<b>U.S. Measure</b>	<b>Metric Measure</b>
<b>Model 7231</b>		
GPM.....	2.0 GPM	(7.6 L/M)
Nozzle Orifice .....	1.8 mm	(1.8 mm)
<b>Model 7232</b>		
GPM.....	3.0 GPM	(11.4 L/M)
Nozzle Orifice.....	2.1 mm	(2.1 mm)
<b>Common Specifications</b>		
Hose Barb .....	1/4"	(1/4")
Tapped Barb .....	8/32" UNF	(8/32" UNF)
Inlet Port .....	M18x1.0	(M18x1.0)
Discharge Port .....	3/8" NPTM	(3/8" NPTM)
Weight .....	5.3 oz.	(0.15 kg)
Dimensions.....	2 x 1 x 1.75"	(52 x 25 x 45 mm)

## CHEMICAL INJECTOR PERFORMANCE CHART

Optional Special Ported Chemical Injector for Unloader Mounting

Standard Pump Model	Injector Orifice Size	Injector Model	Lo-Pressure Nozzle Rating (Max. Downstream) (Press for Injector)	Max. Chem. Draw (0 PSI) (Downstream)	Hi-Press Nozzle "Deduction" (Press drop across Inj.)
2DX20ES	1.8 mm	7231	100 PSI	52 oz/min	100 PSI
2DX30GS	2.1 mm	7232	150 PSI	50 oz/min	125 PSI

Optimum performance of chemical injector occurs with a 35 ft. high pressure hose and a minimum 3/8" I.D. The type of hose, extended lengths, reduced I.D. and fittings may create back pressures in excess of the low pressure nozzle rating and prevent the injector from drawing chemical. See Hose Friction Loss Chart in Service Manual. **Deduct hose friction loss from above low PSI Nozzle. Consult CAT PUMPS for assistance with other options.**

**CAUTION:** Deduct the pressure drop shown in the performance chart from your desired system pressure to arrive at the maximum high pressure nozzle rating. This is essential to avoid over-pressurizing the pump.

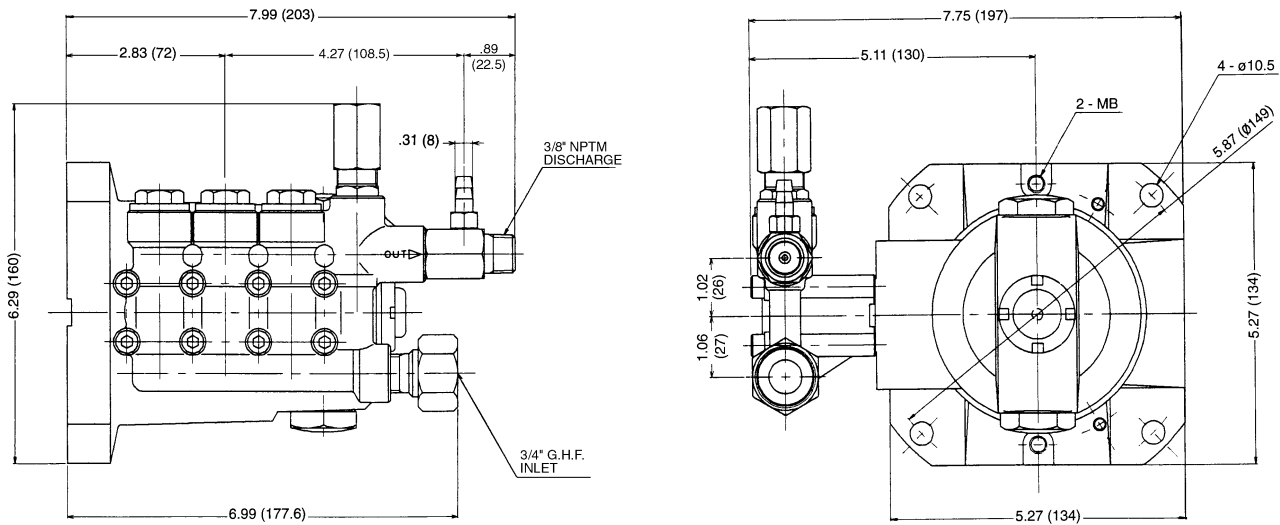

Models 2DX20ES, 2DX30GS

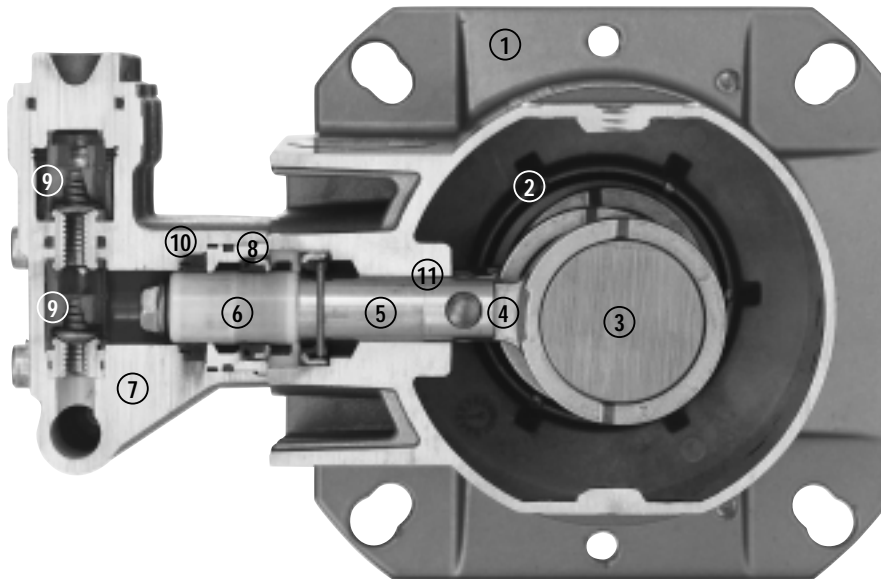

- |  |  |  |
|--|--|--|
| <p><b>1</b> Die cast flange-style aluminum <b>crankcase</b> means high strength, lightweight, and excellent tolerance control.</p> <p><b>2</b> Heavy-duty dual crankshaft <b>bearings</b> provide extended drive-end life.</p> <p><b>3</b> Chrome-moly <b>crankshaft</b> provides unmatched strength and surface hardness for long life.</p> <p><b>4</b> High strength <b>connecting rods</b> assure durability and bearing quality.</p> | <p><b>5</b> Strong brass <b>plunger rods</b> with chrom-moly crosshead pins.</p> <p><b>6</b> Special, concentric, high-density, polished solid ceramic <b>plungers</b> provide a true wear surface and extended seal life.</p> <p><b>7</b> High tensile strength, forged brass <b>manifold head</b> with built-in integral unloader and eight mounting screws for exceptional strength.</p> <p><b>8</b> 100% wet <b>seal</b> design adds to service life by allowing pumped liquids to cool and lubricate on both sides.</p> | <p><b>9</b> Stacked <b>valve assemblies</b> include stainless steel valves, seats and springs to provide corrosion-resistance, ultimate seating and extended life.</p> <p><b>10</b> Unique design and specially formulated <b>Hi-Pressure Seals</b> offer unmatched performance and seal life.</p> <p><b>11</b> <b>Crossheads</b> are 360° supported for uncompromising alignment.</p> |
|--|--|--|

Products described hereon are covered by one or more of the following U.S. patents 3558244, 3652188, 3809508, 3920356, 3930756 and 5035580

**World Headquarters**  
**CAT PUMPS**  
 1681 - 94th Lane N.E. Minneapolis, MN 55449-4324  
 Phone (763) 780-5440 — FAX (763) 780-2958  
 e-mail: techsupport@catpumps.com  
 www.catpumps.com

**International Inquiries**  
 FAX (763) 785-4329  
 e-mail: intlsales@catpumps.com



**CAT PUMPS (U.K.) LTD.**  
 1 Fleet Business Park, Sandy Lane, Church Crookham  
 FLEET, Hampshire, GU52 8BF, England  
 Phone Fleet 44 1252-622031 — Fax 44 1252-626655  
 e-mail: sales@catpumps.co.uk

**N.V. CAT PUMPS INTERNATIONAL S.A.**  
 Heiveldekens 6A, B-2550 Kontich, Belgium  
 Phone 32-3-450.71.50 — Fax 32-3-450.71.51  
 e-mail: cpi@catpumps.be www.catpumps.be

**CAT PUMPS DEUTSCHLAND GmbH**  
 Buchwiese 2, D-65510 Idstein, Germany  
 Phone 49 6126-9303 0 — Fax 49 6126-9303 33  
 e-mail: catpumps@t-online.de www.catpumps.de